

METTIC
SYSTEME

www.metticssysteme.com

MetTec Coupler System

Towards Building Tomorrow

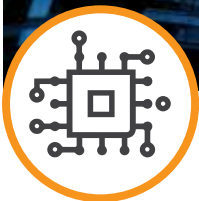

Technology



Innovation



Commitment

METTIC SYSTEME

MetTec Coupler System
MetTec Taper System

MetTec Rotec System
MetTec GT Coupler System

MetTec GripCoupler System
MetTec Anchor Coupler System



INTRODUCTION

METTIC SYSTEME

METTIC SYSTEME is a diversified manufacturer and supplier of premium building products and related technologies for the construction industry. METTIC SYSTEME carries a lot of recognized brands in the construction industry. We are the professional choices for contractors and we are confident that you'll find what you are looking for with our wide product ranges. We put great pride into the relationships and partnerships that we form with our clients.

METTIC SYSTEME presents the engineering solutions to the construction sector with the conception of continuous improvement and high quality. We put great pride into the relationships and partnerships that we form with our clients.

MISSION & VISION

OUR MISSION

To be a preeminent provider of superior Building Material provider in the region by continuously improving the quality of our products and services, adding value for clients through innovation, foresight, integrity and aggressive performance; to maintain highest level of professionalism and integrity in our relationship with our client and employees.

OUR VISION

To be the premier organization operating locally that provides the complete range of quality building materials to all segments under one roof, locally and internationally.

SAFETY, QUALITY, ETHICS & SUSTAINABILITY

METTIC SYSTEME is built upon time tested values of excellence and integrity. This means working to the highest ethical standards and being measured by the enduring quality of our products.

We are committed to leaving legacy of progress by developing local skills for sustained economic opportunity and volunteering our time and talent to the communities where we work.



**SAFETY, QUALITY,
ETHICS & SUSTAINABILITY**

Mettic Systeme is built upon time tested values of excellence and integrity. This means working to the highest ethical standards and being measured by the enduring quality of our products.

WE are committed to leaving legacy of progress by developing local skills for sustained economic opportunity and volunteering our time and talent to the communities where we work.

We Represent





Reinforcement Couplers

For almost 100 years, construction practices in the building of concrete structures have focused on the use of steel reinforcement to transfer the tension and shear forces. Lap splicing has become the traditional method of connecting the steel reinforcing bars, largely due to a misconception that the lap splicing is “no – cost” splicing. Lap splicing requires the overlapping of two parallel bars.

The overlap load transfer mechanism takes advantage of the bond between the steel and the concrete to transfer the load. The load in one bar is transferred to the concrete, and then from the concrete to the ongoing bar. However the Lapped joints are not always an appropriate means of connecting reinforcing bars.

The use of laps can be time consuming in terms of design and installation and can lead to greater congestion within the concrete because of the increased amount of rebar used. Lapped joints are also dependent upon the concrete for load transfer. For this reason any degradation in the integrity of the concrete could significantly affect the performance of the joint.

Reinforcing bar couplers available in the market have come across with a solution for this complexity as it provides a greater ease in design and construction of reinforced concrete and reduce the amount of reinforcement required. The strength of a mechanical splice is independent of the concrete in which it is located and will retain its strength despite loss of cover as a result of impact damage or seismic event.

As a result of changing concepts, ideas, and philosophies, a wide variety of rebar splicing methods has been developed. Reinforcing Bar Coupler’s offer several economic benefits.

Trends toward tougher buildings, increased geography impacted by seismic zone mapping, and governing authority’s desires for safer structures may also impact the potential value of a building.

Inclusion of reinforcing bar coupler today may predate future load path continuity requirements. The negligible short-term perceived economics of lap splicing are far outweighed by the many structural and economic benefits of rebar coupler, including continuity of reinforcing steel, and structural integrity.

METTIC SYSTEME

MetTec COUPLER

Typically, lap joints are provided to connect reinforcement bars for continuity. Though this is simple and easy method, it is not always appropriate or feasible. Advantages of simplicity and economy in lap splicing is limited to smaller diameter bars. However in projects where larger diameter bars are involved, mechanical couplers offer the solution for splicing. Following are some of the advantages of mechanical.



QUALITY, COST & TIME ADVANTAGES

MetTec Coupler System offers quality, cost and time saving. No special skills or equipments are required for fixing couplers. Simple mechanical ways in adopting mechanical splicing compared to lapping, accelerates construction schedules for optimum cost and efficiency. Handling the rebar in convenient sizes saves on valuable crane time. In case of high diameter rebars, considerable length of rebars saves making the Rebar Coupler system economical.

DESIGNER FRIENDLY

In dense reinforcement members, congestion of rebar's is largely reduced by using coupler system. This helps improves concrete flow & consolidation. MetTec Coupler System provides greater flexibility in design options. The simplicity in detailing of reinforcement, particularly in reinforcement congestion zones minimizes the reinforcement fixing errors, detailing and fixing of seismic reinforcement becomes effortless.

TECHNICALLY SUPERIOR

MetTec Coupler System performs like continuous reinforcement. Independent of concrete, splicing develops strength mechanically. Therefore provides ductility in RCC structures independent of condition of concrete. The continuity of spliced rebar offers excellent provision for grounding electrical current.

Applications

- Pour Strips / Construction joints
- Slab Penetrations
- Stairwells
- Tower Crane Openings
- Future Extensions
- Dangerous Starter Bars
- Pile Extensions
- Beam To Column
- Core Walls To Floor Slabs
- Diaphragm Wall

The MetTec Couplers is a full strength, parallel threaded system designed to produce high accuracy, compact, fast and cost effective connections in reinforcing steel.

The system features an enlarged joint area to provide a bar – break connection where 100% of the load can be transferred from the reinforcing steel through the coupled area, providing male threaded bars which are hand tightened. All joints may be used in tensile, compression and shear applications.

Formation Of MetTec Parallel Coupler System



Forging 1



Thread Cutting 2



MetTec Coupler Splicing 3

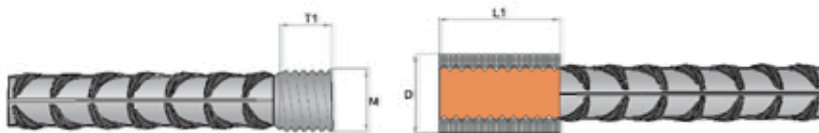

MetTec Coupler - Type A Series

The MetTec Coupler Type A connection utilizes an internally threaded coupler to join two cold – forged and threaded bar ends together. Each bar end is threaded to half the length of the coupler. Type A connections are used where the continuation bar can be rotated.

Code	Rebar Dia	L1	D	T1	M
MSMT16A	16mm	40	26	20	M20
MSMT20A	20mm	48	32	24	M24
MSMT22A	22mm	52	36	26	M28
MSMT25A	25mm	60	40	30	M29
MSMT28A	28mm	66	44	33	M32
MSMT32A	32mm	72	50	36	M35
MSMT36A	36mm	80	56	40	M40
MSMT40A	40mm	90	62	45	M43

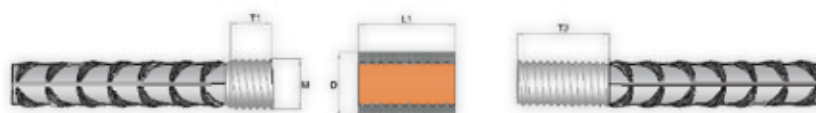

MetTec Coupler - Type B Series

The MetTec Coupler Type B Coupler connection utilizes the same coupler as for the Type A, the difference being one bar end is threaded for the full coupler length. Type B connections are used where the continuation bar can be rotated for no more than one revolution.

Code	Rebar Dia	L1	D	T1	T2	M
MSMT16B	16mm	40	26	20	40	M20
MSMT20B	20mm	48	32	24	48	M24
MSMT22B	22mm	52	36	26	52	M28
MSMT25B	25mm	60	40	30	60	M29
MSMT28B	28mm	66	44	33	66	M32
MSMT32B	32mm	72	50	36	72	M35
MSMT36B	36mm	80	56	40	80	M40
MSMT40B	40mm	90	62	45	90	M43

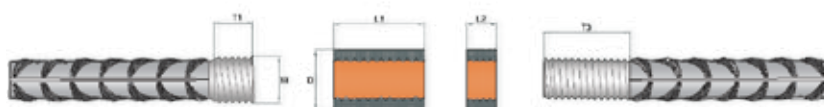

MetTec Coupler - Type B+ Series

The MetTec Coupler Type B+ connection utilizes the same coupler as for the Type A, the difference being one bar end is threaded for the full coupler length. Type B connections are used where the continuation bar can be rotated for no more than one revolution.

Code	Rebar Dia	L1	D	T1	T2	M
MSMT16B	16mm	40	28	20	40	M20
MSMT20B	20mm	48	36	24	48	M24
MSMT22B	22mm	52	36	26	52	M28
MSMT25B	25mm	60	42	30	60	M29
MSMT28B	28mm	66	45	33	66	M32
MSMT32B	32mm	72	52	36	72	M35
MSMT36B	36mm	80	57	40	80	M40
MSMT40B	40mm	90	62	45	90	M43

Rebar End Treatment and Couplers

CUTTING

The rebar end is sawn cut using a bandsaw or circular saw. It can also be shear cut.

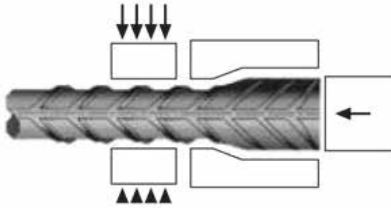

COLD FORGING

For each diameter of reinforcement bar, a hydraulic operated forging machine and specific dies are used to obtain the desired forge on the reinforcement bar.

THREADING

The forged part are then threaded with parallel cuts with ISO threads.

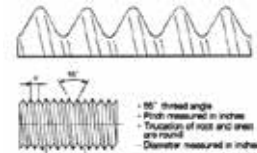

QC CHECK

A final check is conducted using a Thread Checking Gauge with a predefined frequency. This Thread Checking Gauge is used to check the length of the thread and the quality of the threads.



GROUPS OF REQUIREMENTS	NO. SAMPLES 1	NO. SAMPLES 2	NO. SAMPLES 3
Group 1 - Yield	500	500	500
Group 2 - UTS	500	500	500
Group 3 - Elongation after breaking	500	500	500
Group 4 - Yield strength - No slip	500	500	500

GROUPS OF REQUIREMENTS	NO. SAMPLES 1	NO. SAMPLES 2	NO. SAMPLES 3
Group 1 - Yield	500	500	500
Group 2 - UTS	500	500	500
Group 3 - Elongation after breaking	500	500	500
Group 4 - Yield strength - No slip	500	500	500

GROUPS OF REQUIREMENTS	NO. SAMPLES 1	NO. SAMPLES 2	NO. SAMPLES 3
Group 1 - Yield	500	500	500
Group 2 - UTS	500	500	500
Group 3 - Elongation after breaking	500	500	500
Group 4 - Yield strength - No slip	500	500	500

GROUPS OF REQUIREMENTS	NO. SAMPLES 1	NO. SAMPLES 2	NO. SAMPLES 3
Group 1 - Yield	500	500	500
Group 2 - UTS	500	500	500
Group 3 - Elongation after breaking	500	500	500
Group 4 - Yield strength - No slip	500	500	500

GROUPS OF REQUIREMENTS	NO. SAMPLES 1	NO. SAMPLES 2	NO. SAMPLES 3
Group 1 - Yield	500	500	500
Group 2 - UTS	500	500	500
Group 3 - Elongation after breaking	500	500	500
Group 4 - Yield strength - No slip	500	500	500

MetTec Taper Coupler System is a mechanical joint which is designed to withstand horizontal forces and axial forces at the same time.

PROCESSING STEPS

Using Taper Threading Machine to process threads on end of steel bar. Suitable to suit reinforcement bars from diameter 12mm up to 40mm.

Link two ends of steel bar with taper thread coupler and engagement is by tightening using a torque wrench.

ADVANTAGE

- Compact design. Suitable for space restricted area.
- Processing quick and convenient, not be affected by environmental.
- Low processing cost and economical.
- Suitable for top down construction.



Taper Thread Coupler Dimension

Steel Bar Size (mm)	Coupler OD (mm)	Coupler Length (mm)	Pitch (mm)
Φ12	22	45	2.0
Φ16	25	50	2.0
Φ20	30	60	2.5
Φ25	36	80	2.5
Φ28	40	90	2.5
Φ32	45	100	2.5
Φ36	50	110	2.5
Φ40	55	120	2.5

MetTec RoTec Coupler System provides a cost effective, full strength joint which are one of the most efficient and innovative system available for the construction industry.

<p>PROCESSING STEPS</p>		<p>ADVANTAGE</p>
<p>Using Roll Threading Machine to process threads on end of steel bar</p>		<p>The tensile strength of connection equal or exceeds the steel bar strength.</p>
<p>Link two ends of steel bar with coupler</p>		<p>Processing is quick and convenient</p> <p>The transmission performance is better and quality stable</p>
<p>Low processing cost and economical</p> <p>The machine can match chamfering parts to chamfer on steel bar during processing</p>		

MetTec RoTec Coupler Dimension

Steel Bar Size (mm)	Coupler OD (mm)	Coupler Length (mm)	Thread (mm)
Φ16	25	45	M16.7×2.5
Φ18	28	50	M18.7×2.5
Φ20	30	55	M20.7×2.5
Φ22	32	60	M22.7×2.5
Φ25	38	65	M25.7×2.5
Φ28	42	70	M28.7×3.0
Φ32	48	80	M32.7×2.5
Φ36	53	90	M36.7×2.5
Φ40	59	95	M40.7×2.5

MetTec HG Sleeve

HG Sleeve is a kind of half grout sleeve which consists a thread end, where the threaded rebar is turned in at the factory while the portion of the sleeve is grouted on-site. It's Suitable for splicing the rebars in precast column and wall.

Note: The thread end can be manufactured to match your existing rebar threading configuration. we are also able to provide you with all type of threading machines, for either taper threading, cold forged threading and rolled threading machines are available for sales. Full technical support will be provided by us.

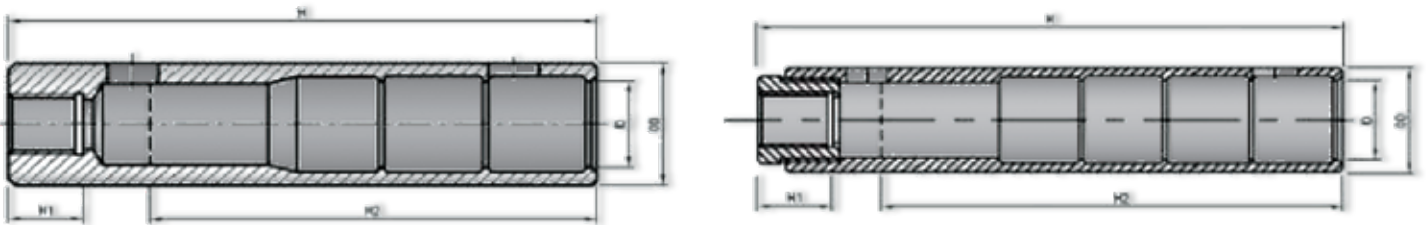

HG12~HG40

Size	Rebar size		Diameter (OD)× Length (H)	Inner Diameter (ID)	Thread Depth (H1)	Rebar Embedment Depth (H2)	Grout Consumption (Kg/pc)
	With Thread Splice	With Grout Splice					
HG12	Φ12	Φ13, Φ12	Φ34×156	25	18	90-127	0.30
HG16	Φ16	Φ16, Φ13	Φ42×174	30	20.5	115-143	0.36
HG20	Φ20	Φ20, Φ16	Φ48×211	34	24	145-175	0.47
HG25	Φ25	Φ25, Φ20	Φ55×256	40	30	182-215	0.67
HG28	Φ28	Φ28, Φ25	Φ58×292	43.5	33	216-244	0.50
HG32	Φ32	Φ32, Φ28	Φ63×330	48	36	246-276	1.07
HC40	Φ40	Φ40, Φ32	Φ80×426	58	45	331-360	1.93

MetTec FG Sleeve

FG Sleeve is a full grout sleeve used when both rebars are joined with grout. It is suitable for splicing the rebars in precast column and wall.

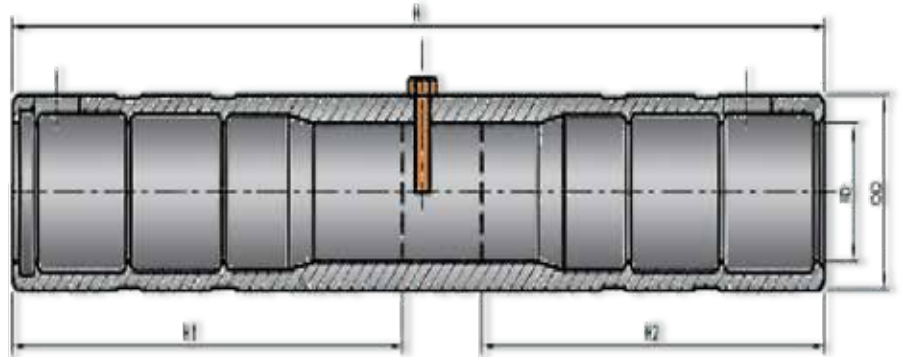

Size	Rebar size	Diameter (O.D)× Length(H)	Inner Diameter (ID)	Thread Depth (H1)	Rebar Embedment Depth		Grout Consumption (Kg/pc)
					In Factory(H1)	On Site(H2)	
FG12	Φ12	Φ37.5×210	25	18	90-94	90-110	0.42
FG16	Φ16	Φ42.5×260	30	20.5	115-119	115-135	0.55
FG20	Φ20	Φ48×320	34	24	145-149	145-165	0.74
FG25	Φ25	Φ55×400	40	30	182-287	182-207	1.08
FG28	Φ28	Φ58×470	43.5	33	216-221	216-241	1.45
FG32	Φ32	Φ63×530	48	36	246-251	246-271	1.79
FG40	Φ40	Φ80×700	58	45	331-336	331-356	3.66

MetTec FGS Sleeve

FGS Sleeve is a full grout slim sleeve used when both rebars are joined with grout on site. It is suitable for splicing the rebars in precast beam.

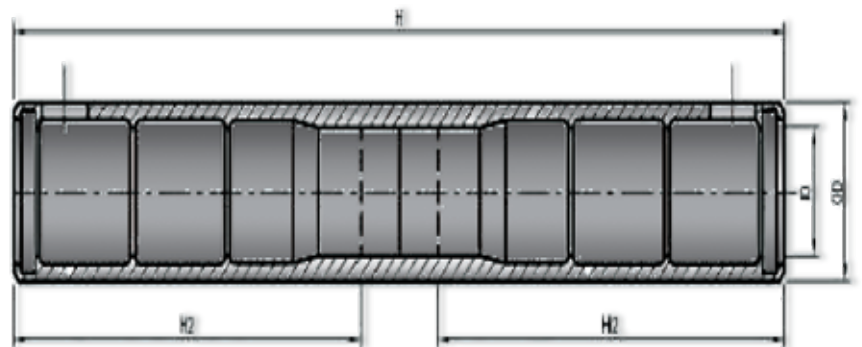

Size	Rebar Size	Diameter (OD)× Length(H)	Inner Diameter (ID)	Rebar Embedment Depth(H2)	Grout Consumption (kg/pc)
FGS20	Φ20, Φ16	Φ42×300	30	135-150	0.38
FGS25	Φ25, Φ20	Φ50×360	36	165-180	0.62
FGS28	Φ28, Φ25	Φ55×410	39	190-205	0.78
FGS32	Φ32, Φ28	Φ60×460	40	215-230	0.96
FGS40	Φ40, Φ32	Φ76×610	53	290-305	1.93

MetTec GripTec Coupler System is a sleeve type coupler that slips over the ends of deformed reinforcing bars and swaged with Mettic System Hydraulic Press to produce a mechanical interlocking between the reinforcement bar and the sleeves. MetTec Grip is suitable for connecting under developed reinforcement bar, new construction, field repair applications and the splicing of older types of reinforcement bar.

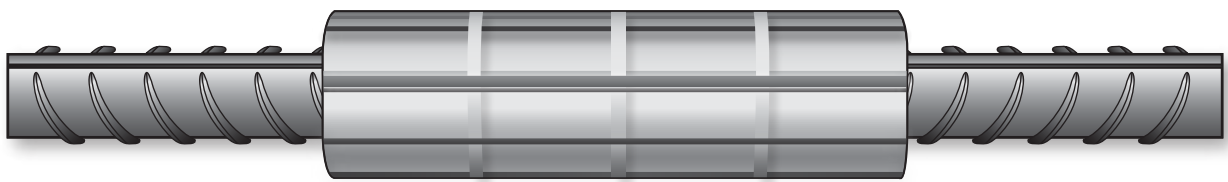

Advantages Of Using **MetTec** **GripTec Coupler System**

The full nominal yield load of the crimped reinforcement bars can be transferred.

Our MetTec Grip System comes in sizes ranging from 16mm – 40mm to perfectly mirror reinforcement bar sizes; it can be installed in any weather conditions and is ideal for both new construction projects and for structural repair solutions.

True structural continuity can be established in reinforcing systems because crimped splice strengths, unlike lap splices, are not dependent upon the compressive strength or cover requirements of the surrounding concrete.

Our MetTec Grip System is a cold forging system, involving no excessive heat therefore retaining the original integrity of the reinforcement bar.

Accessible Visual inspection which allows for simple, non-intrusive quality control, the rebar ends does not require special preparation and the MetTec Grip System mechanical reinforcement splice system splices reinforcement with any galvanized protection or corrugated pattern.

No special bar end preparation is required. The ends can be sheared, sawed, or flame cut; however – a reinforcement bar check is recommended. Bars can be connected from any orientation because special positioning of the press around the bar is not required. In the structure, linear alignment is preserved across the splice by using reinforcement bars with straight ends and securing the loose continuation bar in the desired position at the time of crimping.

Once crimped onto the ribs of the reinforcement, the sleeves secure load transmission by means of a force – locked connection.

**Installation of
MetTec Grip System**

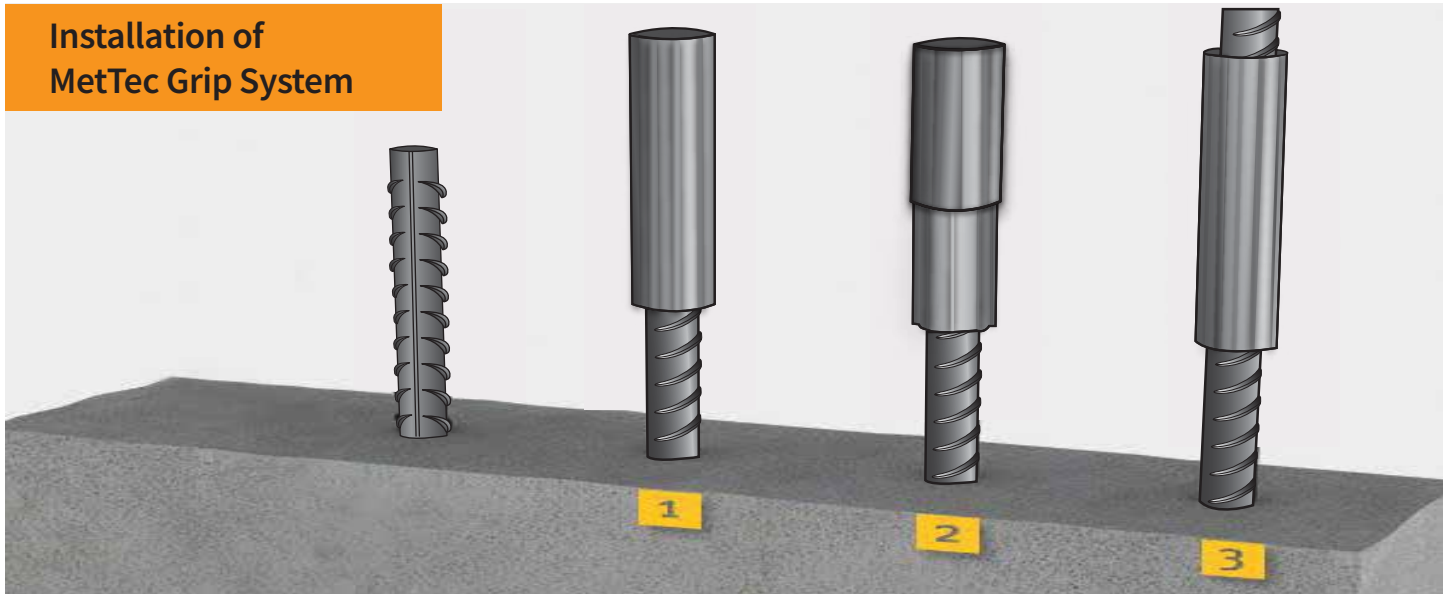

1st Stage

The reinforcement bar is prepared and the sleeve inserted halfway. MetTec Grip System is designed with a stopped in the middle of the sleeves which reduces the tedious work of marking the rebar and sleeves centerline. A hydraulic gripping device is then prepared for the field gripping installation.

2nd Stage

The die set deforms the first half of the coupling sleeve in a radial direction onto the reinforcing bar in a series of overlapping presses.

3rd Stage

The coupling sleeves is slipped over the reinforcement bar which is in the in – situ concrete and the remaining uncrimped portion of the sleeve is crimped.

Notes; On site hydraulic crimping jacks weighs between 20kg to 100kg and this equipment can be supported for use in any orientation. The equipment efficiently half – swage a Grip System sleeves onto the end of a reinforcement bar.

Dimensions Of MetTec Grip System

Product Code	Bar Diameter	Sleeves Dimension (mm)		No of Grips Per End	Pressure (psi)
		OD	Length		
MTGST16	Ø16mm	32	110	Min 3	As Per MS
MTGST20	Ø20mm	38	120	Min 3	As Per MS
MTGST25	Ø25mm	45	160	Min 4	As Per MS
MTGST28	Ø28mm	53	130	Min 4	As Per MS
MTGST32	Ø32mm	57	190	Min 5	As Per MS
MTGST40	Ø40mm	70	250	Min 6	As Per MS

Note: The information in this brochure is considered up to date at the time of publication. We reserve the right to make technical and design changes at any time. Mettic Systeme shall not accept liability for the accuracy of the information in this brochure or for any printing error.

MS – Method Statement



Reasons & Advantages

Cold crimping technology for mechanical splicing of reinforcement bars is one of the most established, developed and refined splicing methods worldwide. Key to cold crimping success is its simplicity, low cost and adaptability. There is no loss of reinforcement bar cross-section area at the splice location

Mechanical crimping with reinforcement bar deformations, lugs or protrusions is the basis of crimped splice strength. The “Slip Test” values of crimped mechanical splices are minimal due to the tight conformation of sleeves to the profile of the bar. Best of all, true structural continuity can be established in reinforcement systems because crimped splice strengths, unlike lap splices, are not depended upon the compressive strength or cover requirements of the surrounding concrete.

In comparison to manual arc welding, cold crimping splices are faster to install, require a lower skilled level, do not require a chemistry determination of the reinforcement bar being spliced, do not require pre – heating or post – heating of the reinforcement bar and do not require radiographic examinations.

Type	By Name	Description
Bar to Bar	MTGST Series	Reinforcement bar mechanical splices shall be the tension – compression crimped sleeve type, which can be installed by octagonal dies to achieve strength.
Bar to Structural Steel	MTGSW Series	Bar-to-structural steel connections shall be the crimped weldable connector type, with weld levels at one end inclined 30° to the rebar axis and pressed to the reinforcement bar at the other end by octagonal dies.

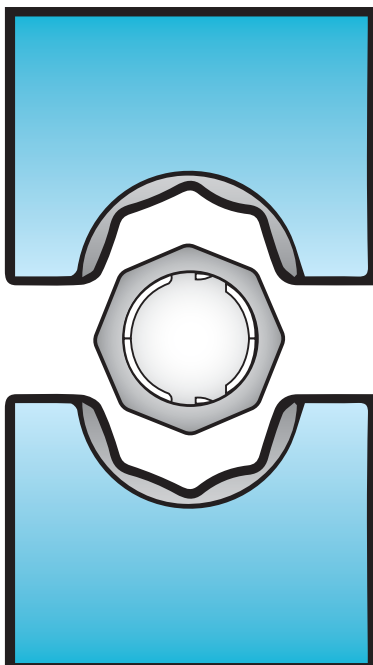

MetTec Other Solutions

MetTec ReduTec
Couplers

MetTec EndTec
Couplers

MetTec WeldTec
Couplers

MetTec LockTec
Couplers

Notes:

Information on above mentioned MetTec Other Solutions can be shared upon request.





Mettic Systeme Sdn Bhd (1169100-K)

Star Avenue Commercial Center
18-02, Block B, Jalan Zuhal U5/178
Seksyen U5, 40150 Shah Alam
Selangor, Malaysia

T/F: +603 7734 1902

E: info@metticsysteme.com

W: www.metticsysteme.com